

The Building Performance Solution For Asset Owners

BBL Seminar

16/11/2020



Solving “The Market For Lemons” Problem

In our used car example, asymmetric information can make it **impossible** to buy a good used car !

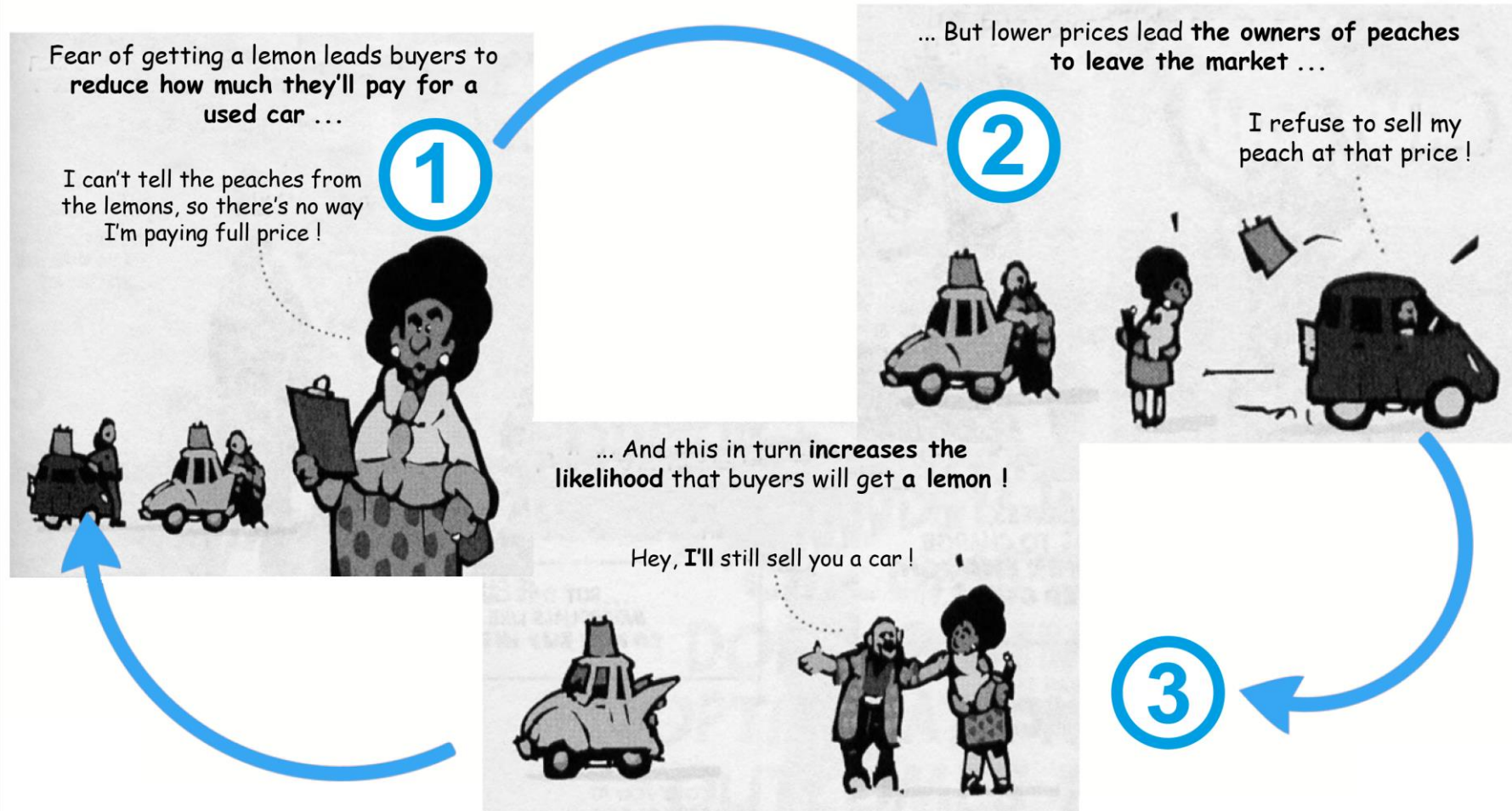

■ Delivering “Cost-Optimum”

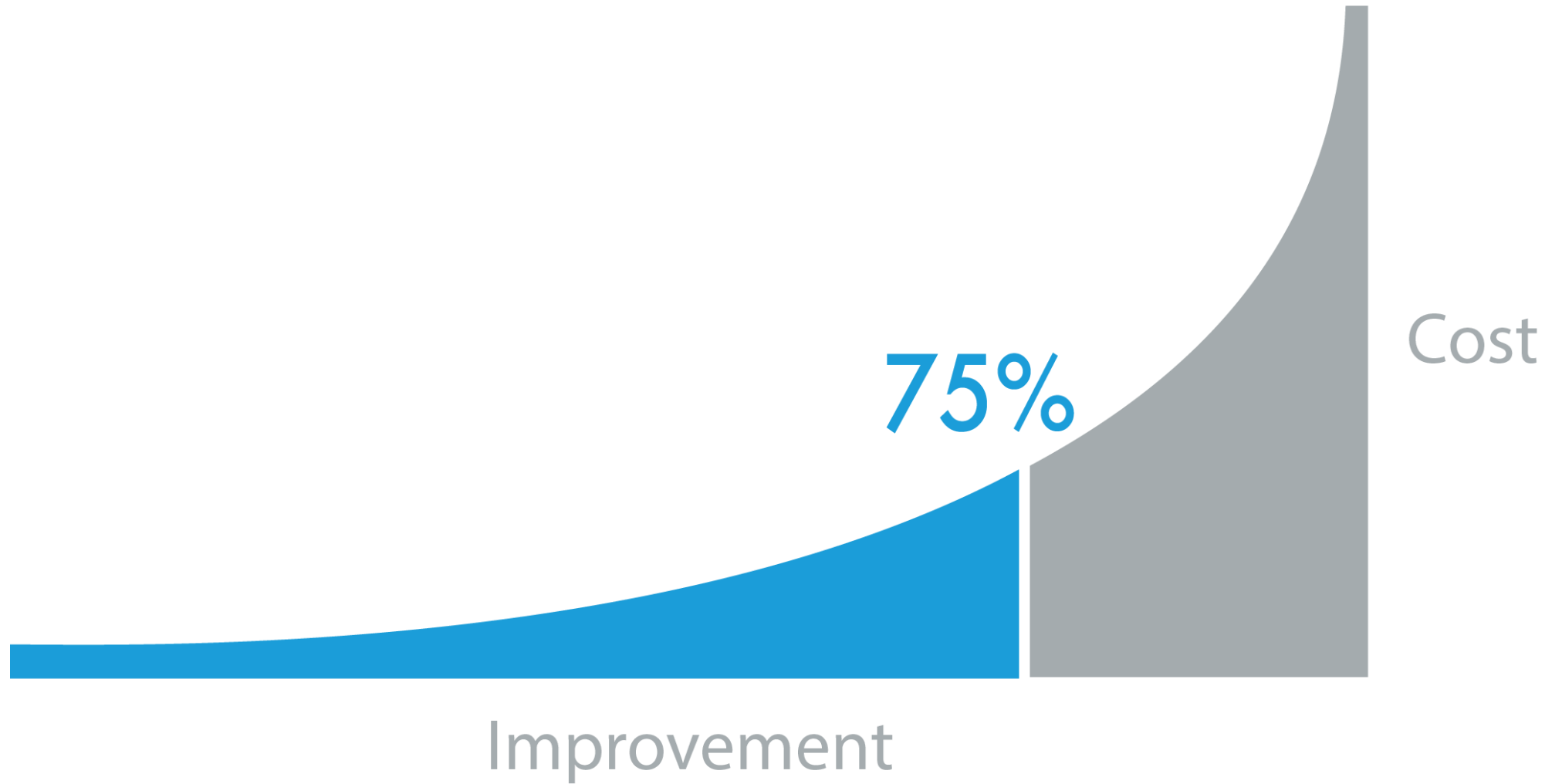



FOR THE FIRST TIME
We can meter energy efficiency
the same way as energy generation

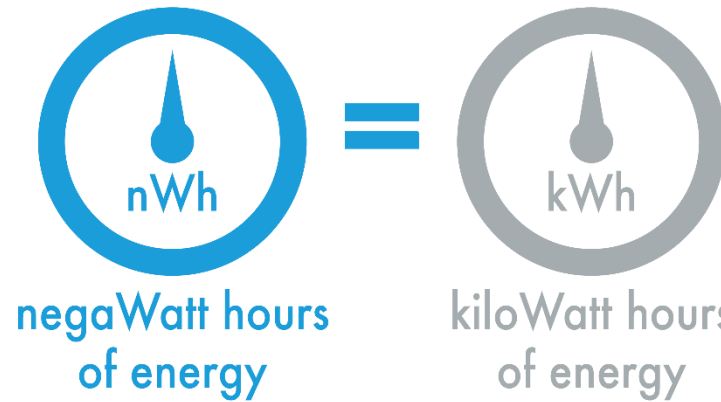

Now energy savings can be calculated day-after-day,
fabric energy performance properly benchmarked
& feedback loops provided on design / quality of works

Smart Connected Sensors & Actuators

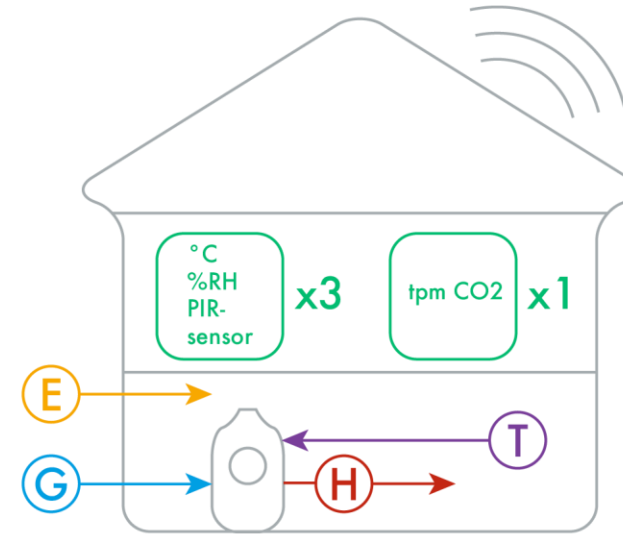



E Electricity Meter

G Gas Meter

H Heat Meter on Central Heating Circuit

T Smart Thermostat

 Boiler (supplying domestic hot water and heating on separate circuits)

 Sensor boxes placed in representative zones according to house size and layout



The NegaWatt Hour (nWh) Meter

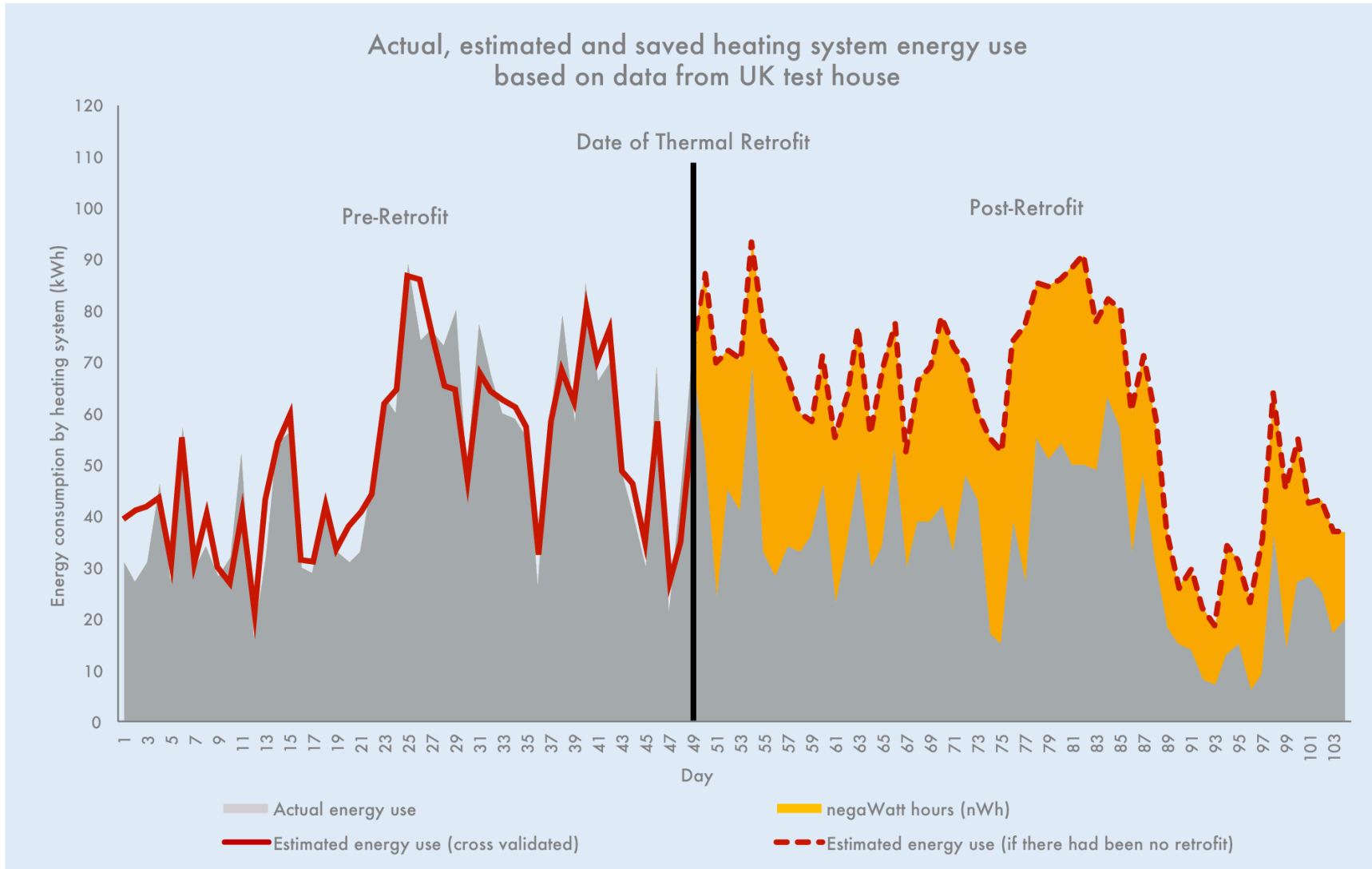



Cavity & Roof Retrofit Improves EDI by 50%

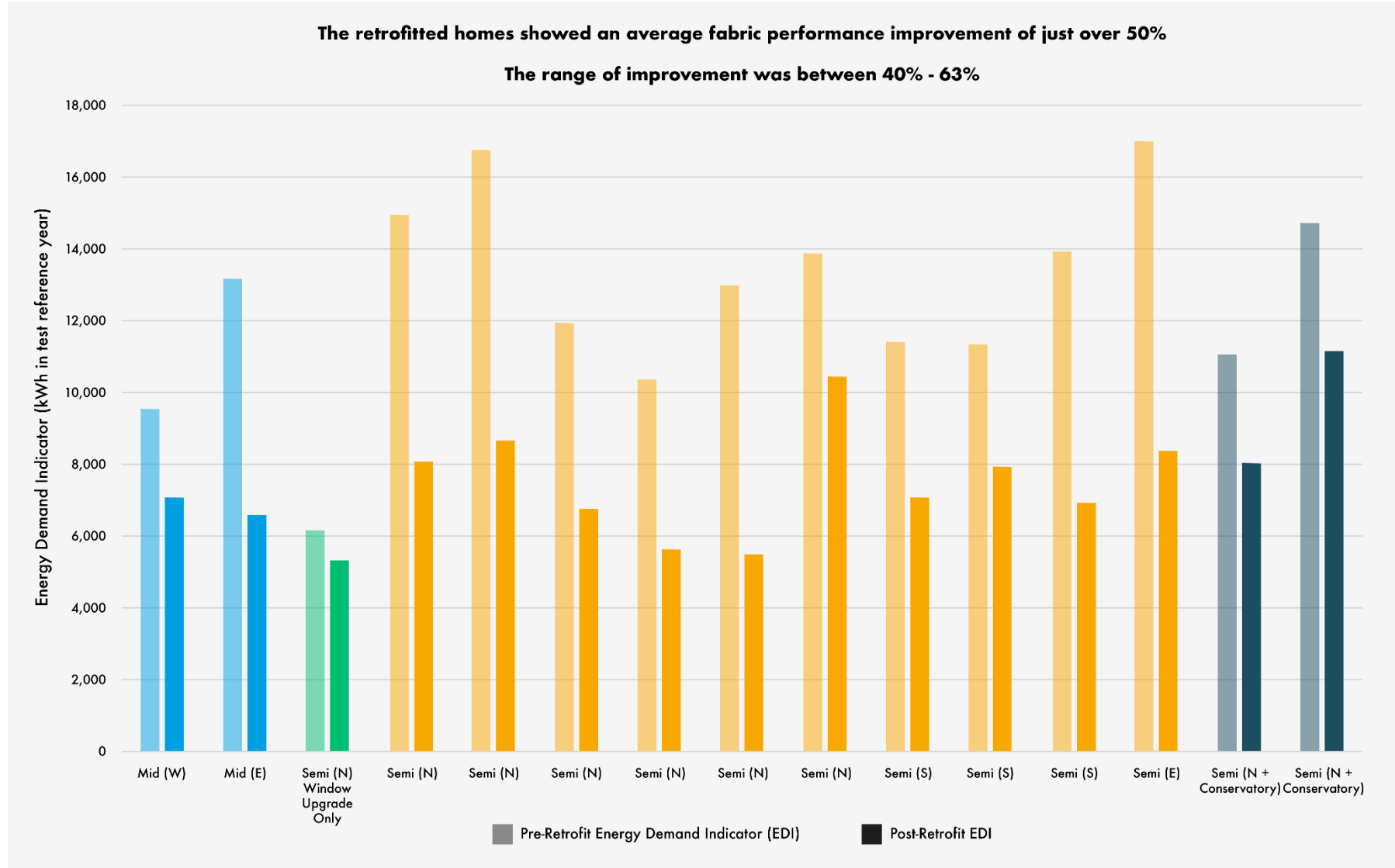



Delivered As A “One-Stop-Shop”



TENDER



KIT INSTALL



KIT PRE MONITORING



COST OPTIONEERING & DESIGN EXCELLENCE



RENOVATION & QUALITY ASSURANCE



KIT POST MONITORING



SMART HOME



CUSTOMER RELATIONSHIP MANAGEMENT



COLLABORATIVE PLANNING



TENANT ENGAGEMENT





Enabling An Improved Solution

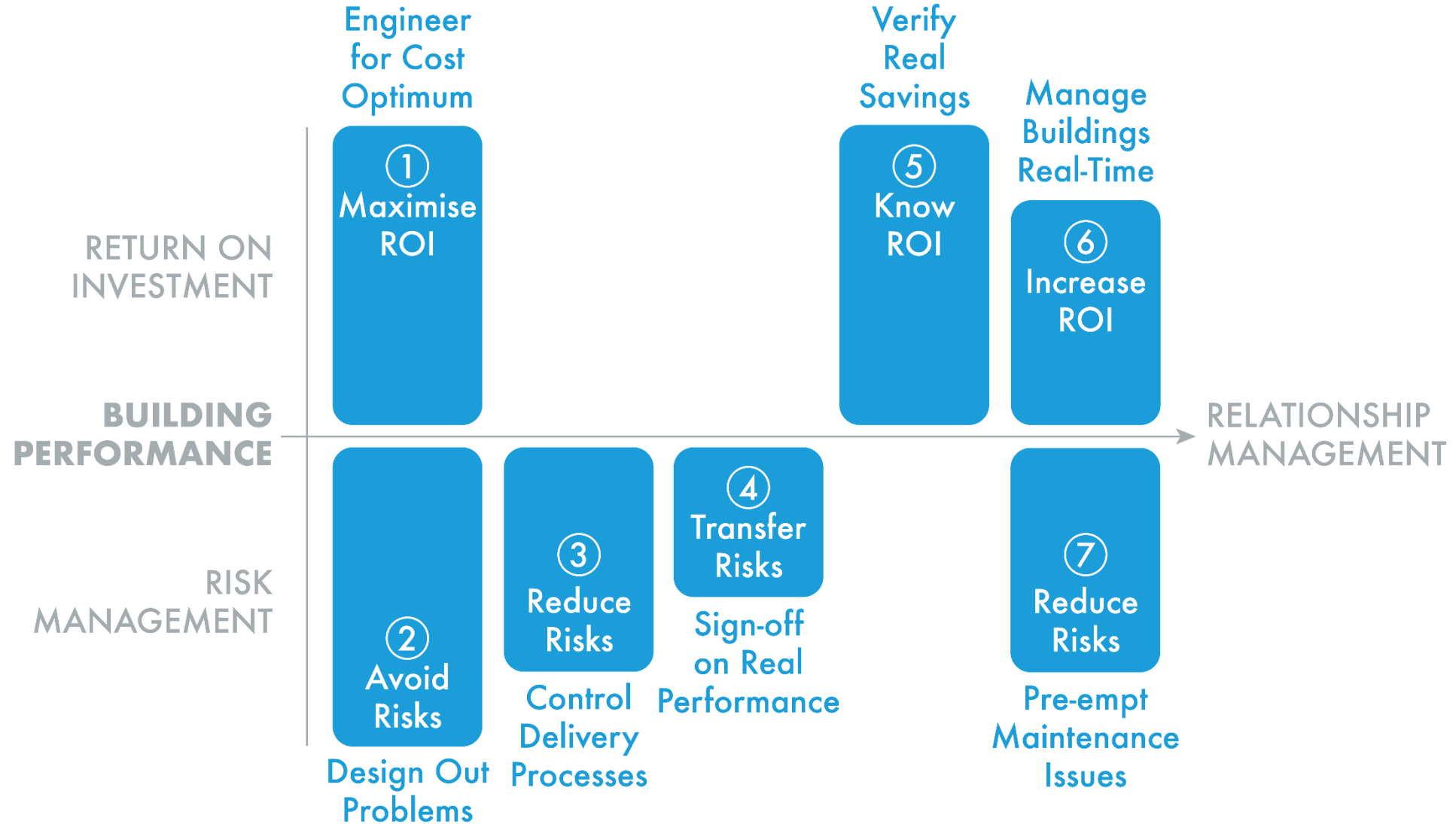

Build The World's Virtual Energy Infrastructure



=



400,000 SMART
RETROFIT HOMES

ONE POWER
STATION

paid for by
Feed-OUT-Tariffs
or power savings agreements

at an unbeatable price



Reorient Towards Our First Fuel

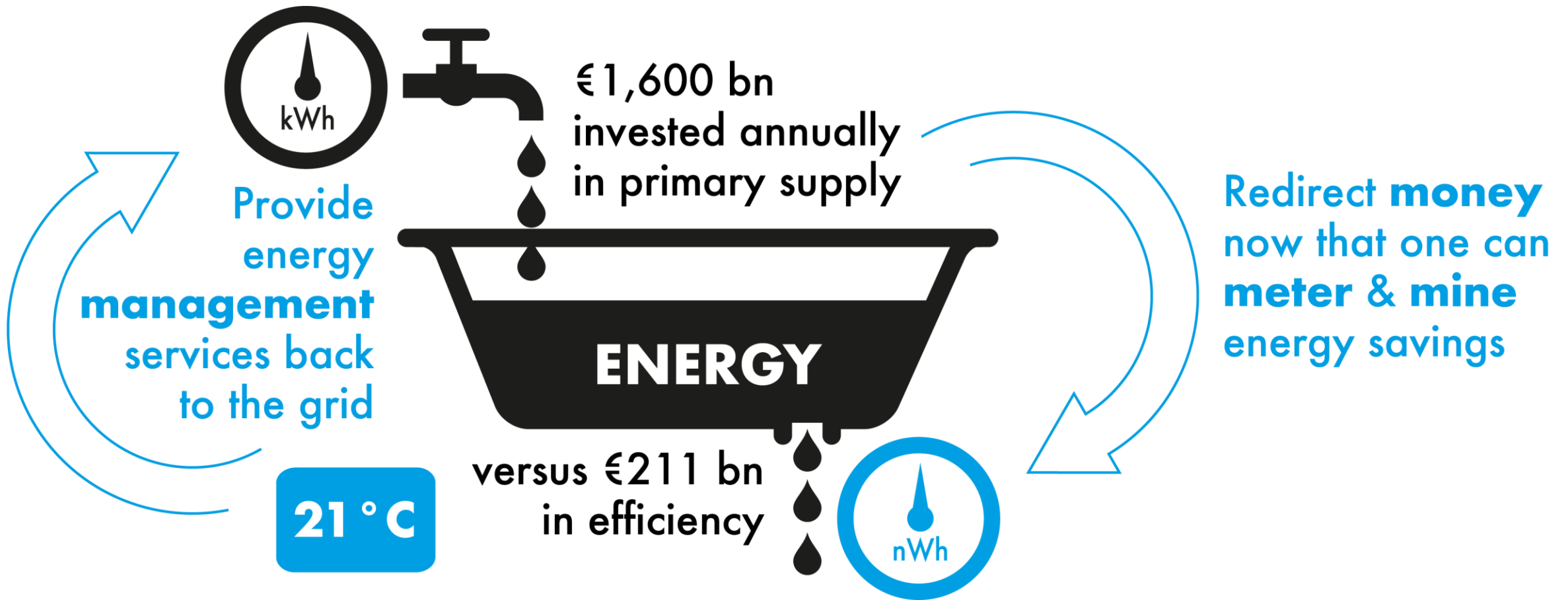



MORE INFORMATION

James Thorogood

Head of Market Development, BENELUX

Knauf Energy Solutions

Email: James.Thorogood@knaufenergy.com

Phone: +32 (0)2 460 26 50 Mobile: +32 (0)476 61 04 18